

GASOLINE-POWERED

5400 NEW

Variable Speed & Clean Output Voltage

The 5400 GPU combines a standard gen-set with a 2400, 400 Hz solid-state converter. It is the first of its kind that runs at variable speed. The automatic adjustment of the engine speed to match changing capacity needs, means a reduction of the noise.

The 5400 is equipped with ITW GSE's Plug & Play voltage compensation system. This patented system provides an optimal output voltage at the aircraft connector, right where it matters.

With its gasoline-powered engine, the 5400 is a low-emission alternative.



115 ± 3 V
UNIQUE VOLTAGE QUALITY



It's all about connections



SPECIFICATIONS

5400 gasoline-driven 90 kVA mobile GPU

Engine

- Ford (EDI) WSG-1068 gasoline engine operating at 1760 to 2800 RPM
- 6.8 Liter V-10
- Full application approval by Engine Distributors Inc.
- 12 VDC battery system
- Variable engine speed based on load
- HP: 201

Engine Protection

- Low oil pressure shutdown
- High coolant temperature shutdown
- Intake air restriction indication

Environmental

- Operating temperature: -25°F to +125°F (-32°C to +52°C)
- Relative humidity: 10-95% non-condensing
- No altitude de-rating required up to 350 ft. then 4% for every 1000 ft. (engine power)

Performance

- Continuous rating: 90 kVA (72 kW), 3 phase, 4 wire, 115/200 V
- Meets or exceeds MIL-STD-704F, SAE ARP5015A and ISO 6858 power quality requirements
- Line drop compensation assures proper voltage at aircraft plug

Dimensions

- Length: 116.2" (2951.7 mm)
- Width: 66.2" (1681.6 mm)
- Height: 70.4" (1789.1 mm)

Weight

- 4500 lbs. (2041 kgs)

Instrumentation

- ITW GSE User Interface – simple to use
- 5-Button directional menu arrow keypad
- Language selection
- Simple operation / status / prompts
- Setup functions
- Engine data
- Output power data
- Fault data
- Memory recall

Electrical Characteristics

- Power: 90 kVA PF 0.8-1
- Voltage: 3 x 115/200 V
- Frequency: 400 Hz 3 0.1%
- Power factor: 0.7 lagging to 0.95 leading
- Voltage regulation: <0.5% for balanced load and up to 30% unbalanced load
- Voltage recovery: ΔU <8% and rec. time <10 ms at 100% load change
- Total harmonic content: <2% of at linear load (typ. 1.5%) <2% at non linear load according to ISO 1540
- Crest factor: 1.414 33%
- Voltage modulation: < 1.0%
- Phase angle symmetry: 120° ± 1° for balanced load 120° ± 2° for 30% unbal. load

Protection

- Per MIL-STD-704F, SAE ARP5015, and ISO 6858
- Over/under voltage
- Over/under frequency
- Overload

Overload

- Continuous 100% rated load at PF 0.8
- Continuous 80% rated load at PF 1.0
- 5 minutes 100% rated load at PF 1.0
- 10 seconds 120% rated load at PF 0.8
- 2 seconds 150% rated load at PF 0.8

Standard Features

- ITW GSE User Interface
- Fifth wheel steering
- Low load shut down
- 75 gallon (284 L) fuel tank with at least 8 hours run time @90 kVA, PF 0.8
- Fork lift pockets
- Tow bar brake
- Tow Bar CE Compliant
- Sliding canopy for ease of access
- Digital control system

Standards

- EPA/CARB compliant
- MIL-STD-704F, SAE ARP5015 and ISO 6858 compliant
- ISO 9001-Certified manufacturer
- CE Compliant

Options

- 28.5 VDC rectifier, 600 amps continuous, 2000 amps peak
- Unit operating light
- Low fuel beacon
- Clearance lights
- Battery blanket
- Military Interlock
- Towbar Interlock
- Tie down rings
- DIN40 towing eye

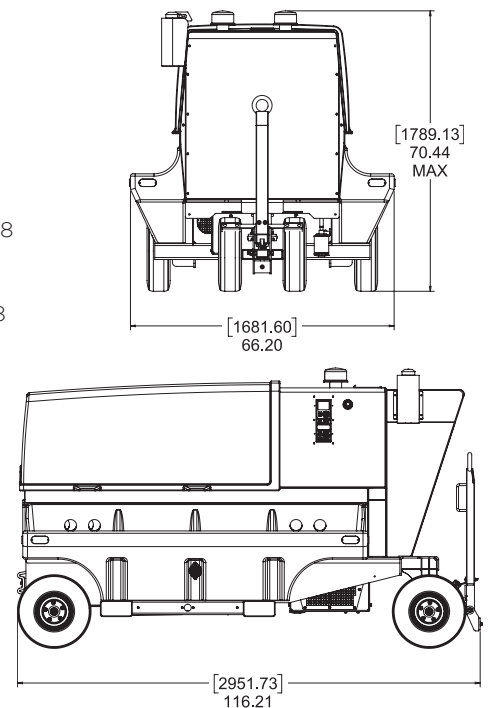

Dimensions are shown in mm and [inches]