

LIGHT TOWER

RL™ 4



Genie®
A TEREX BRAND

TAKING
YOU **HIGHER**™
GENIELIFT.CO.UK



Light Tower

RL™ 4

Specifications

Lamps	Metal halide 4 x 1,000 W
Generator	Brushless 60 Hz, 6.0 kW
Engine	Kubota® diesel 13.6 hp
Receptacles	One GFI duplex 20 A / 120 V One T/L 30 A / 240 V
Fuel capacity	30 gal (114 L)
Wheel size	13" (33 cm)
Axle rating	2,000 lbs (907 kg)
Tongue weight travel position	199 lbs (91 kg)
Total weight no fuel	1,725 lbs (783 kg)

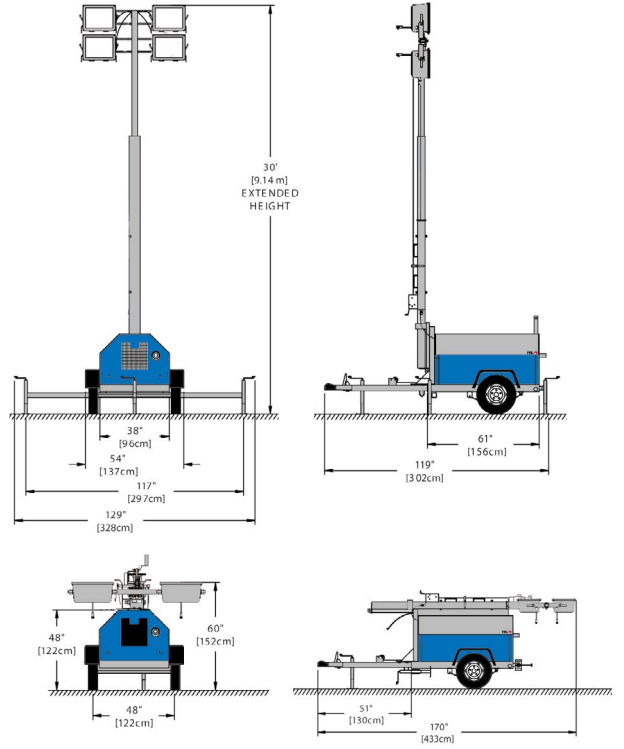

Notice: Metal halide lamp bulbs contain mercury (Hg). Dispose of lamp bulbs according to local, state and federal laws.

Chassis Options

- Genie® branding and blue paint
- Dome light with switch, 12V
- Export racking and preparation
- Hitch, 2 5/16 in. ball
- Hitch, combination ring and ball
- Spare tire and wheel
- Hitch, 2 1/2 in. ring

Engine Options

- 6 kW, 60 Hz generator with 15.3 hp Perkins® diesel
- 7 kW, 50 Hz generator with 13.6 hp Kubota® diesel
- Automatic air shutdown
- Fuel/water separator filter
- Fuel/water separator with fuel line heater

Tower Options

- 4 horizontally mounted lights, cast aluminum square housing
- 19" lamps 4 X 1000W metal halide lights

Cold Weather Options

- Cold weather package including: 700 CCA battery, battery heater blanket, engine block heater and low temperature coolant (-40F)

Features

- 16" lamps 4 X 1000 W metal halide lights with Kubota engine and 6kW generator which provides quiet 71 dBA at 23 feet and fuel efficient 60 hour run time.
- Durable 30' fully galvanized mast with dual self-braking winch design, 359 degree rotation, and retractable mast cable gives excellent illumination at long distances.
- Standard engine protection includes high water temperature and low oil auto shutdowns.
- Quick disconnect lights and ballasts allow for easy troubleshooting, service, and repair.
- Standard DOT approved run, stop and turn lights
- Compact design allows up to 10 units per truck while single point lifting eye and forklift pockets provide for easy loading and unloading
- Highway safety chains with snap hook

Middle East

PO Box 282325, Dubai, United Arab Emirates, T: +971 4 399 0381, Fax +971 4 399 0382, Email AWP-Infome@terex.com

United Kingdom

The Maltings, Wharf Road, Grantham NG31 6BH, T: +44 800 988 3739 (toll free), Fax +44 (0)1476 584334, Email AWP-InfoEurope@terex.com
Visit www.genielift.co.uk/locations to view our global locations list.

Worldwide Manufacturing And Distribution

Australia • Brazil • Caribbean • Central America • China • France • Germany • Italy • Japan • Korea • Mexico • Russia • Southeast Asia • Spain • Sweden • United Arab Emirates • United Kingdom • United States

Effective Date: September, 2014. Product specifications and prices are subject to change without notice or obligation. The photographs and/or drawings in this document are for illustrative purposes only. Refer to the appropriate Operator's Manual for instructions on the proper use of this equipment. Failure to follow the appropriate Operator's Manual when using our equipment or to otherwise act irresponsibly may result in serious injury or death. The only warranty applicable to our equipment is the standard written warranty applicable to the particular product and sale and we make no other warranty, express or implied. Products and services listed may be trademarks, service marks or trade names of Terex Corporation and/or their subsidiaries in the USA and many other countries. Genie is a registered trademark of Terex South Dakota, Inc. © 2014 Terex Corporation.

