

# SPECIFICATIONS

## MEASUREMENTS

Lamps	Metal halide 4 x 1,000 W
Generator	Brushless 60 Hz, 8.0 kW
Engine	Kubota® diesel 13.6 hp
Receptacles	One GFI duplex 20 A / 120 V One T/L 30 A / 240 V
Fuel capacity	30 gal (114 L)
Wheel size	15 in (38 cm)
Axle rating	3,500 lbs (1,558 kg)
Tongue weight travel position	167 lbs (76 kg)
Total weight no fuel	2,239 lbs (1,016 kg)

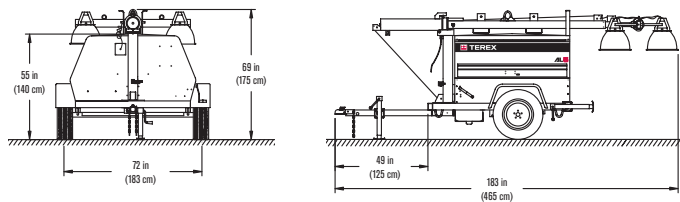
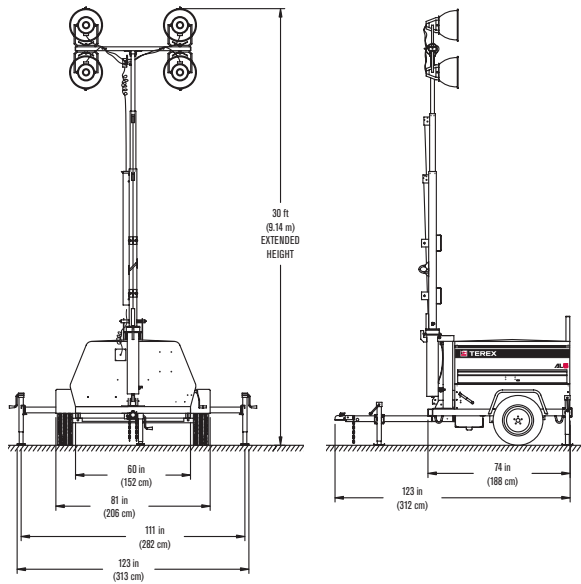

Notice: Metal halide lamp bulbs contain mercury (Hg). Dispose of lamp bulbs according to local, state and federal laws.

## FEATURES

4 X 1000 W metal halide lights with Kubota engine and 8kW generator.

Option for up to 20kW generator with plenty of extra power to run all of your tools.

Durable 30 ft (9.18 m) fully galvanized mast with single self-braking winch design, 359 degree rotation, and retractable mast cable gives excellent illumination at long distances.

Standard engine protection includes high water temperature and low oil auto shutdowns.

Quick disconnect lights and ballasts allow for easy troubleshooting, service, and repair. Internal storage system for light fixtures provides safekeeping and protection during transport.

Standard DOT approved run, stop and turn lights

Heavy duty mast, chassis, and 3,500 lbs (1,558 kg) rated axle to handle rough road towing.

Highway safety chains with snap hook



## AL™5 LIGHT TOWER



## CHASSIS OPTIONS

30 gal fuel tank w/ spill containment

60 gal fuel tank

60 gal fuel tank w/ spill containment

Export racking and preparation

Extra GFI duplex receptacle with breaker

Hitch, 2 1/2 in. ring

Hitch, 2 5/16 in. ball

Hitch, combination ring and ball

Rubber door hold-down latches

Spare tire and wheel

Tough coat paint surface: cabinet and trailer front

Trailer brakes, electric

Trailer brakes, Hydraulic surge: must specify ring or ball hitch

## ENGINE OPTIONS

12 kW, 60 Hz generator with 16.3 hp (12.1 kW) Kubota® diesel

20 kW, 60 Hz generator with 29.2 hp (21.7 kW) Isuzu turbo diesel, includes external receptacle package, and 2 ea. 20A/120V GFI & 3 ea. 30A/240V T/L, 700 CCA battery

Automatic air shutdown

Fuel/water separator filter

Fuel/water separator with fuel line heater

## TOWER OPTIONS

6 metal halide lights

Electric winch

## COLD WEATHER OPTIONS

Cold weather package: 700 CCA battery, battery blanket heater, engine block heater, low temp coolant (-40°F)

Deluxe cold weather package: 1000 CCA battery, battery blanket heater, engine block heater, low temp coolant (-40°F)

Aviation Ground Equipment Corp.  
53 Hanse Avenue, Freeport NY USA  
Tel: 1(516) 546-0003 | 1(800) 758-0044  
Email: Sales@AviationGroundEquip.com  
Web: www.AviationGroundEquip.com