

# HOBART 4400

Mobile diesel-driven 60 & 90 kVA GPU  
Cummins QSB4.5 diesel engine  
ITW GSE Generator  
TIER 4 Final / EU STAGE 4



**ITW  
GSE** **HOBART**

It's all about connections

# Specifications

## HOBART 4400 mobile diesel-driven 60 kVA & 90 kVA GPU

### Engine

- Cummins QSB4.5 diesel engine operating at 2000 RPM
- Tier 4 Final / EU Stage 4 compliant
- Turbocharged 4-stroke, inline 4 cylinder common rail fuel system
- Full application approval by Cummins
- 24 VDC battery system
- Electronic governor system (via the engine's ECM)
- Intake manifold pre-heater for cold weather starting
- HP: 155 (90 kVA), HP 110 (60 kVA)

### Engine Protection

- Low oil pressure shutdown
- High coolant temperature shutdown
- Low coolant level warning
- Intake air restriction indication
- Low fuel warning

### Environmental

- Operating temperature: -25°F to +125°F (-32°C to +52°C)
- Relative humidity: 10-95% non-condensing
- No altitude derating required up to 12,000 ft. (3,658 meters) when running in normal operating range

### Performance

- Continuous rating: 60 kVA (48 kW) 90 kVA (72 kW), 3 phase, 4 wire, 115/200 V
- Meets or exceeds MIL-STD-704F, SAE ARP5015A and ISO 6858 power quality requirements
- Line drop compensation assures proper voltage at aircraft plug

### Dimensions & Weight

- Length: 110.9" (2817 mm)
- Width: 66.2" (1681 mm)
- Height: 64.5" (1639 mm)
- 4200 lbs. (1905 kgs) dry weight, no cables, no ARU
- 4500 lbs. (2041 kgs) dry weight, no cables, with ARU

### Color

- White canopy, black cable trays, galvanized chassis. Other colors available on request.

Specifications are subject to change without prior notice

**HOBART is part of ITW GSE**  
- the world's leading supplier of Ground Support Equipment

### Instrumentation

- Icon based ITW GSE user interface
- 5-Button directional menu arrow keypad
- Multiple language capability
- Simple operation / status / prompts
- Setup functions
- Engine data
- Output power data
- Fault data
- Memory recall

### Electrical Characteristics

- Voltage regulation:  $\pm 1\%$  no load to full load
- Voltage adjustment:  $\pm 15$  volts
- Max. line drop compensation: 5%
- Individual harmonic distortion:  $< 1\%$  of the fundamental (RMS) voltage
- Total harmonic distortion:  $< 2\%$  of the fundamental (RMS) voltage
- Voltage & frequency transients meet MIL-STD-704F, SAE ARP5015A, and ISO 6858 (BS2G219)
- Phase voltage balance not to exceed 1% on a 3-phase balanced load and does not exceed 4% with 33% unbalanced load
- Frequency regulation:  $\pm 2$  Hz steady state

### Protection

- Per MIL-STD-704F, SAE ARP5015, and ISO 6858
- Over / under voltage
- Over / under frequency
- Overload

### Overload

- 80% load at PF  $> 0.8 - 1.0$  - Continuous
- 100% load at PF  $> 0.7 - 0.8$  - Continuous
- 100% load at PF  $> 0.8 - 1.0$  - 5 Minutes
- 100% to 120% load (PF 0.7 - 0.8) - 10 Seconds
- 120% to 150% load (PF 0.7 - 0.8) - 2 Seconds
- Individual outputs: 217/325 amps, 5 minutes (60/90 kVA)

### Standard Features

- ITW GSE designed and manufactured generator
- ITW GSE user interface
- Fifth wheel steering
- No load shut down
- 53 gallon fuel tank (200 L) with at least 8 hrs. run time at max full load
- Fork lift pockets
- Tow bar with parking brake
- Sliding canopy for ease of access

### Standards

- EPA Tier 4(f)/CARB Tier 4
- EU Stage IV
- MIL-STD-704F, SAE ARP5015 and ISO 6858
- BS2G219
- ISO 9001-Certified manufacturer
- CE certified

### Options

- 28.5 VDC Active rectifier (simultaneous operation with 400 Hz), 600 amps continuous, 2000 amps peak
- Unit operating beacon
- Low fuel beacon
- Clearance lights
- Block heater
- Battery blanket
- Second 400 Hz output
- DIN40 towing eye
- Military Interlock
- Towbar Interlock
- Tie down rings

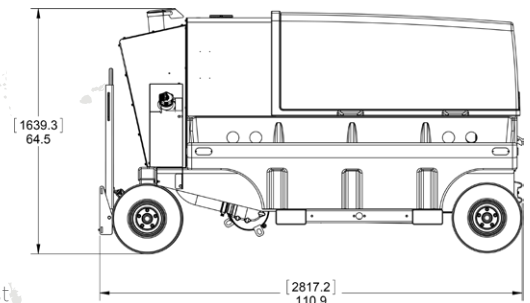
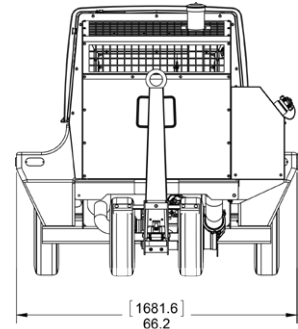

**ITW GSE HOBART**

It's all about connections