



DAC900 Mobile Pre-Conditioned Air Unit



Model DAC900 Trailer Mounted

TRILECTRON:

Trilectron Industries and air-a-plane products division have led the industry in product design and innovation. The best combination of experience, new technology and customer input has resulted in a product line you can trust for your aircraft's needs.

APPLICATION:

Completely self-contained diesel powered PCAir unit for comfortable conditioning of wide body and jumbo passenger aircraft cabins. Endurance: approximately 8 hours of continuous operation per full fuel tank.

OPTIONS:

Units can be trailer mounted for towing or truck mounted on a suitable chassis (consult factory). Power for the Generator/Engine set can be Detroit Diesel, Perkins Cummins or Deutz. All engines are diesel and jet fuel compatible.

CE AND EMISSIONS CERTIFIED:

All engines meet current Tier Emissions Certifications as specified by EPA and CARB. CE Certification and international labeling is an added feature of this equipment.

PERFORMANCE FEATURES:

Proven design:

- Hermetic scroll compressor refrigeration circuits with oversized condensing coils
- Finned-tube enclosed element electric resistance heaters
- Aluminum box frame and panels
- ETL tested, listed and labeled
- Meets all UL, NEMA, CE, NEC, OSHA, NFPA, ASHRAE, ASME and AHM 73 & 74 standards

Easy to Operate:

- Simple lighted button operator station mounted at ramp level
- Automatic DDC controls determine appropriate mode and output temperatures

Economical:

- Blower fan mounted directly to the fan motor requiring no clutches, gears or pulleys
- Less moving parts equate to lower maintenance costs
- High efficiency output through the use of multiple refrigerant circuits in a "cascading series" arrangement
- Significantly less cost than running the aircraft APU

Durable:

- Designed to endure the rigors of the airport environment
- Easy access to all components for maintenance

Model	Cooling Capacity	Heating Capacity	Length	Width	Height	Weight
DAC900	90 Tons (318 kW)	204.4 kW	221" (561 cm)	102" (259 cm)	108" (274 cm)	18,500 lb (8,391 kg)

Trilectron's DAC900 Mobile Pre-Conditioned Air Unit Specifications

CONSTRUCTION

- Base Unit Weight: 18,500 lb
- Painted steel frame construction
- Aluminum body access panels and doors with stainless steel hardware
- NEMA 4 Electrical enclosure and weather tight wiring conduit
- Large operational switches, buttons and latches for cold weather operation in heavy gloves

FINISH

- Anti-corrosive polyester powder provides excellent weather resistance, flexibility and adhesion, plus a strong resistance to chemical agents such as glycol and skydrol
- Standard colors are high gloss white over black frame
- Custom colors require a paint chip or swatch for accurate color match

PERFORMANCE

- Nominal Cooling Capacity: 90 tons
- Nominal Airflow: 500 ppm (3.78 kg/s)
- Nominal Static Press: 37"wg (9.22 kPa)
- Nominal Electric Heater: 90 kW, 4 stg
- Nominal Water Heater: 27.9 kW
- Rating Condition: 95°Fdb/78°Fwb (35°Cdb / 26°Cwb), 460/3/60, R22, sea level
- Rated Cooling Capacity: 1,080,600 Btu/hr (316.7 kW)
- Rated Condenser Airflow: 76,000 CFM (35,866 L/s)
- Rated Condensate Flow: 0.71 GPM (45 mL/s)
- Rated Heat Output (Blower+Heater+Engine): 697,400 Btu/hr (204.4 kW)
- Refrigerants: R22, R134a, 407c
- Regional temperatures and elevation affect unit performance. Consult factory for specific unit selection data.

ENVIRONMENTAL

- Operation Temperature: -40° F to +125° F (-40° C to + 52° C)
- Relative humidity 0-100%

ELECTRICAL

- Blower Motor: 60 HP (44.7 kW)
- Condenser Fan Motors: 6 @ 3 HP (6 @ 2.2 kW)
- Electric heater (optional): 90 kW, 4 stage, finned-tube enclosed element

CONTROL

- 24VAC Control Voltage
- Manual and Automatic Mode Selection
- Damper Airflow Control
- Operator panel with large lighted momentary push buttons

GENERATOR/ENGINE SET

Generator

- AC output: 480V, 3PH, 4 wire
- Marathon Continuous Duty Alternator

Engine

- Detroit Diesel, Cummins, Perkins or Deutz
- Turbocharged 4-stroke, inline 6 cylinder
- Diesel and Jet Fuel Compatible

PROTECTION

Air Conditioning

- High discharge air temperature (with heat option)
- Airflow loss
- High refrigerant pressure
- Low refrigerant pressure
- Circuit breakers and overloads on all motors

Engine

- High Temperature Shutdown
- Low Oil Pressure Shutdown
- Overvoltage Shutdown
- Undervoltage Shutdown
- Overcrank Starting Protection
- Output Circuit Breaker

DISPLAYS/INSTRUMENTATION

- Meters: Discharge air temperature, fuel level, hour meter, water temperature, oil pressure, battery volt meter
- Indicator Lights: Lighted pushbuttons (see below)
- Buttons: Start, stop, mode, Aircraft class selection

AVAILABLE OPTIONS

Configuration

- 14"D Insulated, Flat Air Delivery Hoses (2)
- Electric/Hot Water Heat System
- Truck Mounted (consult factory)
- Exterior hazard lights
- Shore Power Cable & Switch
- Proximity Crash Rail
- CE Package
- Low Fuel Warning Beacon
- Operation Indicator beacon
- Special paint scheme

Engine

- Engine Block Heater
- Ether Cold Start
- Racor® Fuel Filter

Specifications subject to change without notice.

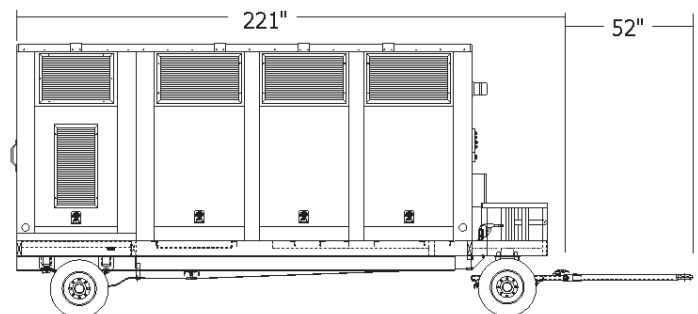
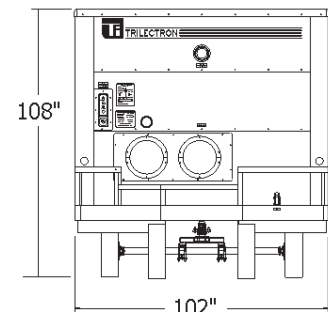

THE GSE GROUP
TRILECTRON
INDUSTRIES

Updated 04/04/03

Aviation Ground Equipment Corp.

53 Hanse Avenue, Freeport, NY 11520 U.S.A.

Phone: (516) 546-0003 • Fax: (516) 546-0198

E-mail: sales@aviationgroundequip.com • www.AviationGroundEquip.com